

GUIDANCE ON USE OF PRODUCER STATEMENTS

This producer statement has been prepared by a combined task committee consisting of members of the New Zealand Institute of Architects, Institution of Professional Engineers New Zealand, Association of Consulting Engineers New Zealand and the Building Officials Institute of New Zealand.

Four producer statements are available and brief details on the purposes of each are as follows:

- Design:** Intended for use by the person responsible for the design in circumstances where the territorial authority will rely on the producer statement to issue a building consent.
- Design Review:** Intended for use by suitably qualified independent design professional where the territorial authority does not undertake an internal review and relies on the independent design professional's review to issue the building consent.
- Construction:** Intended for use by the contractor of the building works where the territorial authority requires a producer statement at the completion of construction.
- Construction Review:** Intended for use by the person required by the building consent to undertake construction monitoring of the building works in circumstances where the territorial authority will rely on the producer statement to issue a Code Compliance Certificate.

The producer statements system is intended to provide territorial authorities with reasonable ground issuing of a building consent or Code of Compliance Certificate without having to duplicate design or construction checking by others.

The following criteria are recommended by the territorial authorities with respect to the use of the producer statements.

Definition of Suitably Qualified Design Professional

A suitably qualified design professional should have recognised qualifications and experience for the work undertaken and should be either:

- (i) an active member of the Association of Consulting Engineers of New Zealand (ACENZ) or;
- (ii) a corporate member of the Institution of Professional Engineers of New Zealand (IPENZ) having a current policy of Professional Indemnity Insurance for a sum not less than \$200,000 or;
- (iii) a member of the New Zealand Institute of Architects (NZIA) having a current policy of Professional Indemnity Insurance for a sum of not less than \$200,000.

Design Build Contracts

If the design professional is engaged by the contractor, the territorial authority should satisfy itself that it is appropriate for the territorial authority to rely upon a producer statement from the design professional.

Consulting Services during Construction Phase

There are several levels of service which a design professional may provide during the construction phase of a project. The territorial authority is encouraged to require that the service to be provided by the design professional is appropriate for the project concerned.

Requirement to provide Producer Statement

Territorial authorities should ensure that the applicant is aware of any circumstances in which there may be a requirement for producer statements for the construction phase of building work at the time the building consent is issued as no design professional should be expected to provide a producer statement unless such a requirement forms part of the design professional's engagement.

Attached Particulars

Attached particulars referred to in this producer statement refer to supplementary information appended to the producer statement.

PRODUCER STATEMENT & TECHNICAL SPECIFICATIONS FOR



FOLDED POOL FENCE



Folded Pool - Technical Installation Specifications & Producer Statement

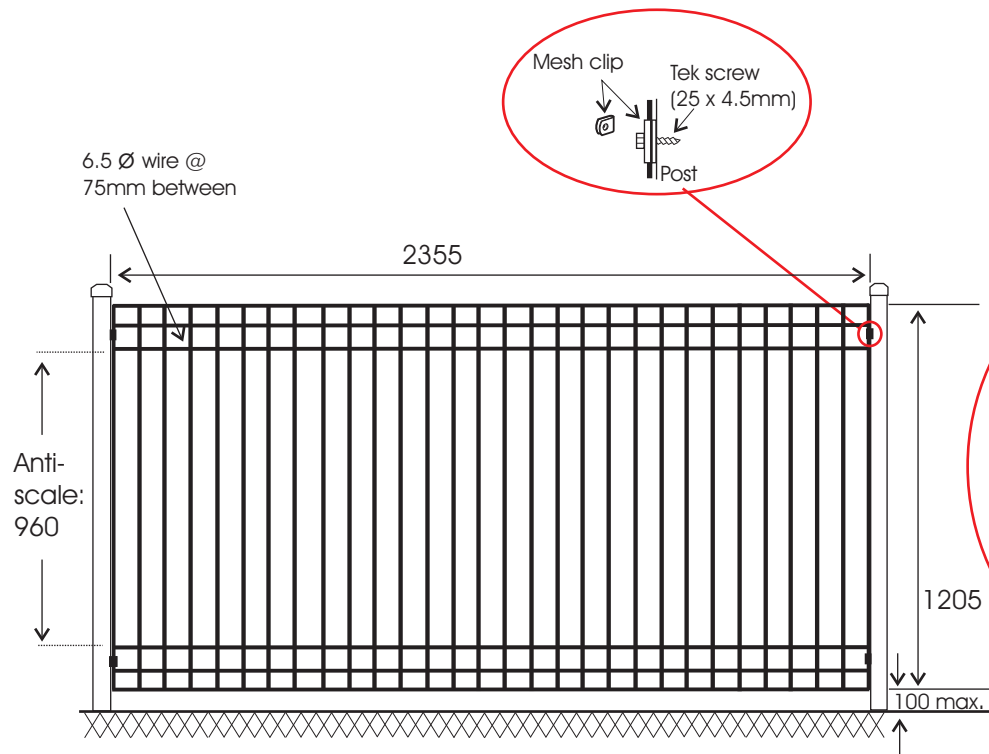

Installing the Folded Pool fence on sloping ground.

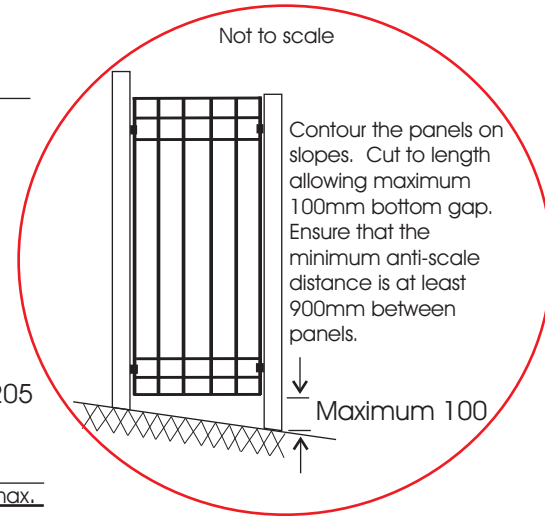

Folded Pool Pedestrian Gate

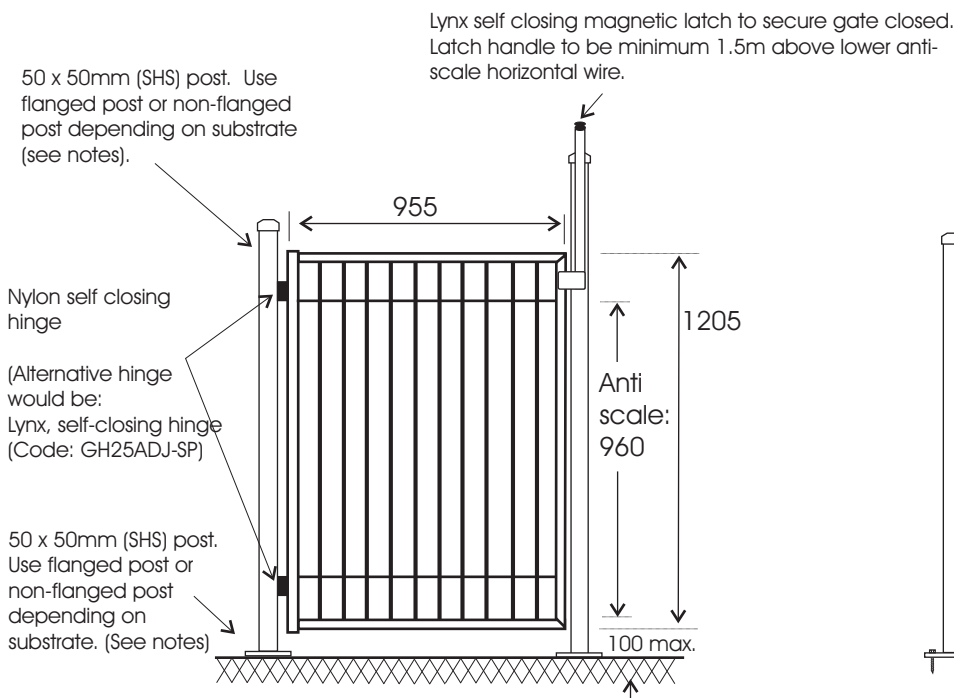

Flanged Post Installation

Installation into wood:
4 x galv coach screws 12 x 100

Installation into hard surface:
4 x galv dynabolt 12 x 100

Flange is 125 x 125 x 5mm.

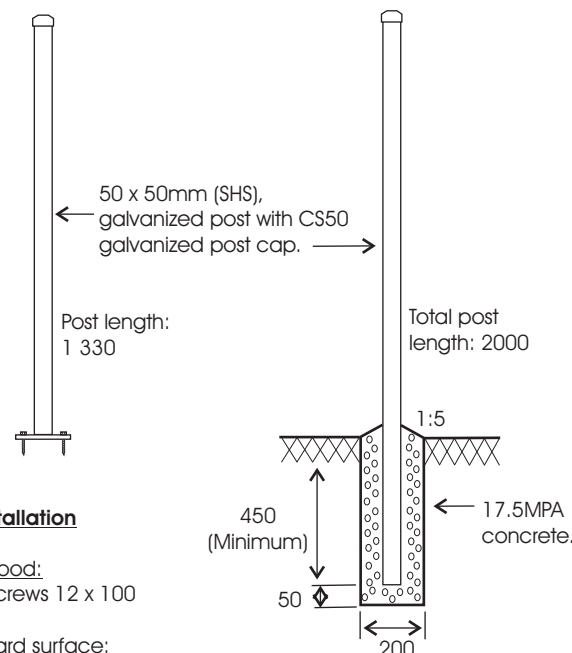

Notes:

1. Fence panel is hot dip galvanized with average minimum zinc thickness of 450g/m²
2. Gate is hot dip galvanized with average minimum zinc thickness of 450g/m²
3. Powder coating is optional & recommended
4. Posts either pre-galvanized (average minimum zinc thickness of 90g/m²) or hot dip galvanized (average minimum zinc thickness of 450g/m²)
5. Depending on the ground conditions, a larger hole size may be required for securing the post (please consult with a suitably qualified engineer.)

Scale - 1 : 24
Drawing Size - A3
Drawing No. - F.P-2.4(75-2)H
Date - September 2011



DBH Act(s) FSPA(1987)

PRODUCER STATEMENT - PS1 - DESIGN

(Guidance notes on the use of this form are printed on the reverse side*)

ISSUED BY: Nancekivell Cairn Ltd
(Design Firm)

TO: Advanced Steel Products Ltd
(Owner/Developer)

TO BE SUPPLIED TO: Various
(Building Consent Authority)

IN RESPECT OF: 99562 - ASPL - New Pool Barrier System
(Description of Building Work)

AT: Non-Specific
(Address)

LOT _____ DP _____ SO _____

We have been engaged by the owner/developer referred to above to provide Checking of ASPL Boss, Duke, Max, Folded Panel and Noble Pool Barrier Systems to ensure compliance with the Act only services in respect of the requirements of

Clause(s) Fencing of Swimming Pools Act 1987 (2008 Reprint) as part of the Department of Building and Housing for
 All or Part only (as specified in the attachment to this statement), of the proposed building work.

The compliance checks carried out by us has been prepared in accordance with:
 Compliance Documents issued by the Department of Building & Housing Fencing of Swimming Pools Act 1987 (2008 Reprint) (verification method/acceptable solution) or
 Alternative solution as per the attached schedule

The proposed building work covered by this producer statement is described in the drawings attached

On behalf of the Design Firm, and subject to:

- (i) Site verification of the following assumptions Structure supporting the barrier to be designed on a case by case basis
- (ii) All proprietary products meeting their performance specification requirements;

I believe on reasonable grounds the fence, if constructed in accordance with the drawings, specifications, and other documents provided or listed in the attached schedule, will comply with the relevant provisions of the Act.

I, Bruce Graham Nancekivell am: CPEng 30994 #
(Name of Design Professional) Reg Arch _____ #

I am a Member of: IPENZ NZIA and hold the following qualifications: BE (Civil) - AC #1044

The Design Firm issuing this statement holds a current Professional Indemnity Insurance no less than \$200,000*.
The Design Firm is a member of ACENZ YES NO

SIGNED BY Bruce Graham Nancekivell ON BEHALF OF Nancekivell Cairn Ltd
(Design Firm)

Date 25-Aug-11 (signature)

Note: This statement shall only be relied upon by the Building Consent Authority named above. Liability under this statement accrues to the Design Firm only. The total maximum amount of damages payable arising from this statement and all other statements provided to the Building Consent Authority in relation to this building work, whether in contract, tort or otherwise (including negligence), is limited to the sum of \$200,000*.

This form is to accompany Form 2 of the Building (Forms) Regulations 2004 for the application of a Building Consent.